

Technical Bulletin

Technical Helpline: +44(0)1622 833004 Fax: +44(0)1622 834004

Product Information: **ADG06290** Manifold Repair Kit

Applications: Daewoo/Chevrolet Matiz 800cc

Date Issued: 07/2011

BLUE
PRINT

Solutions

A common problem on the 800cc Daewoo/Chevrolet Matiz is corrosion to the alloy cylinder head and distortion (Warping) of the plastic inlet manifold, resulting in a coolant leak between the two. The plastic inlet manifold on this three cylinder engine includes a 'blanking plate' moulded to the end which seals against a water-way on the cylinder head. Over time the plastic deteriorates, eventually resulting in a coolant leak. ADG06290 is an inlet manifold repair kit to give a long term cure to this particular problem, comprising of a high quality blanking plate and modified manifold gasket. Carrying out the modification is straightforward and is illustrated below.

ADG06290

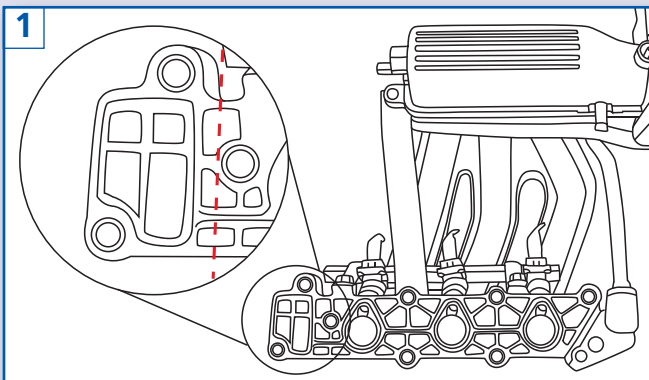

Once removed from the car, hold or carefully clamp the plastic inlet manifold. Mark the coolant blanking section of the manifold that you are about to saw through, making sure that you mark a section slightly larger than the size of the new blanking plate. This is to ensure there is no interference between the manifold and new blanking plate when they are fitted to the engine. Check twice – cut once!

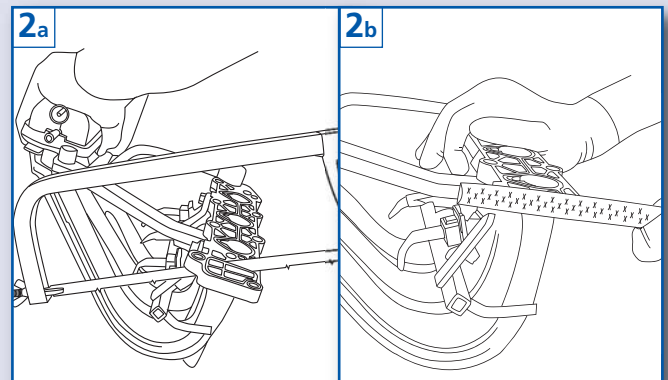

Plug the three outlet ports to prevent debris falling into the manifold. Carefully saw through the manifold and remove the old blanking section. Then trim/file the rough edges of the manifold to ensure a flat mating surface is maintained and clean as necessary

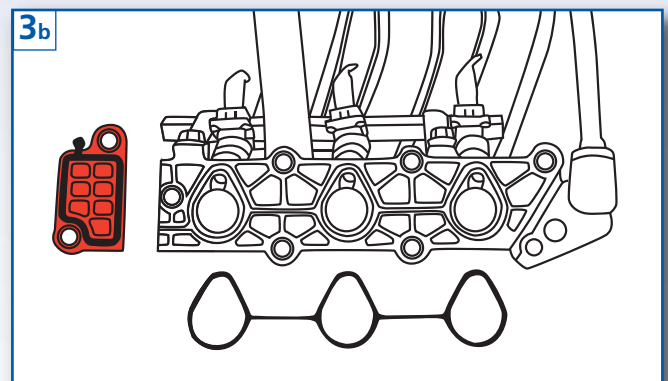
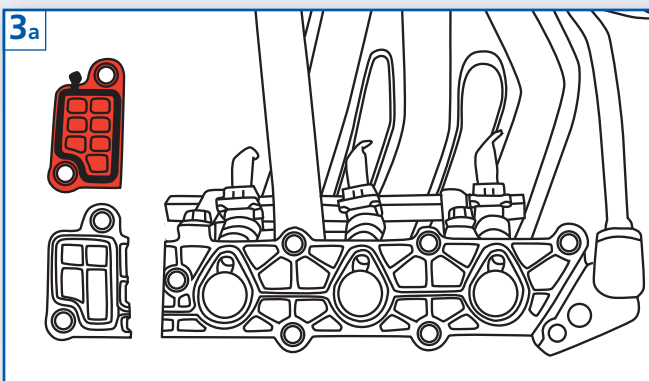

Ensure that the mating surface of the cylinder head is clean and refit the manifold using the new manifold gasket supplied. Fit the new blanking plate onto the cylinder head, using a little RTV if required. Tighten all manifold nuts to the manufacturer's specifications. (15-19Nm)

Additional points:

Re-connect everything. Top up engine coolant as necessary. Run engine and re-check for coolant leak.

Repair time:

Manifold replacement = 1.2hrs

Allow further 20>30mins for modification.

Disclaimer : Any technical tips are produced in good faith. Automotive Distributors Ltd. always recommends that vehicle maintenance and diagnostics are only carried out by suitably experienced people using appropriate tools in a safe manner within a workshop environment. Automotive Distributors Ltd. and its customers cannot be held responsible for the correctness of, or misinterpretation of the above technical tips. Images shown are for illustrative purposes only and may not be representative of the products or vehicles described.



www.blue-print.com