

Technical Bulletin

Technical Helpline: +44(0)1622 833004 Fax: +44(0)1622 834004

Isuzu Trooper Rear Caliper Application ADZ94507R and ADZ94508R (UBS52 and UBS55 models)

Date Issued: 01/05/04

Rear Caliper Slider Length Option

Some of the **ADZ94507R** and **ADZ94508R** Trooper applications will have either a **55mm** or **74mm slider tube fitted** in the original caliper (see diagrams below). From April 2002, our calipers will be fitted with a 55mm slider, and include an additional 74mm slider kit (labelled 8914006), which may be used as required. The caliper boxes containing the additional kit can be identified by a yellow 'Important Information' label on the outside of the box.

The length of the original vehicle slider tube MUST be checked and the appropriate tube fitted to the replacement unit prior to installation. If the incorrect length of tube is fitted, it will result in the retainer bolts being the wrong length.

- If the slider length in the replacement caliper matches the original in the vehicle, the caliper is ready to fit.
- If the slider needs to be exchanged, remove the rubber cap and carefully slide the tube out of the caliper (taking care not to damage the grease retaining boot). Lightly grease the alternative slider tube surface with a silicone type grease (ensuring there is no grit or dirt contamination) and fit in the reverse order. Ensure that the rubber boot locates into the slider pin groove.

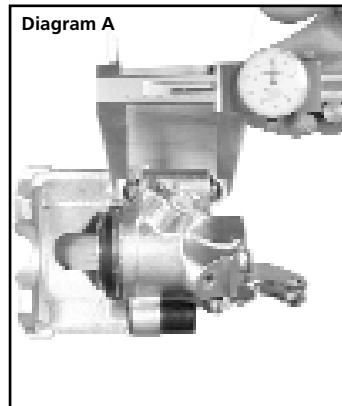
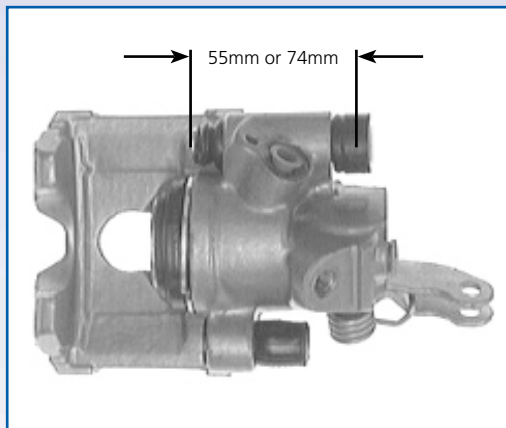
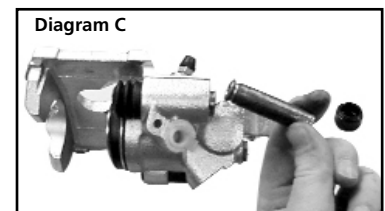
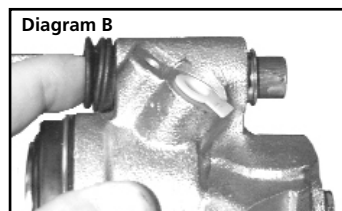
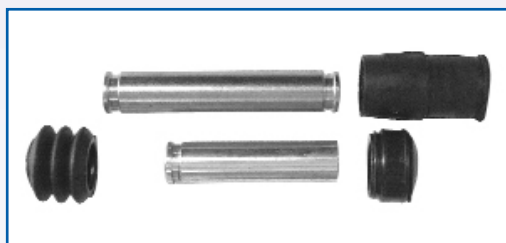

Diagram A shows slider length being measured with both boots removed

Diagram B and C show slider tube being removed



THE UN-USED SLIDER TUBES MUST BE RETURNED WITH THE ORIGINAL CALIPER TO RECLAIM THE UNIT SURCHARGE COST.

Disclaimer : Any technical tips are produced in good faith. Blue Print, always recommend that vehicle maintenance and diagnostics are only carried out by suitably experienced people using appropriate tools in a safe manner within a workshop environment. Blue Print, and their customers cannot be held responsible for the correctness of, or misinterpretation of the above technical tips. Images shown are for illustrative purposes only and may not be representative of the products or vehicles described.

**BLUE
PRINT**
www.blue-print.com