

# Technical Bulletin

## PSA & FIAT IVECO F1CE3481N/D/E (F30DT)

### TCK194NG/TCK195NG vs. TCK194LNG/TCK195LNG

#### Fitting Position: Upper

**TCK194NG** - Engine number to: 1442629 & up to emission standard: Euro IV

**TCK194LNG** - Engine number from: 1442630 & from emission standard Euro V

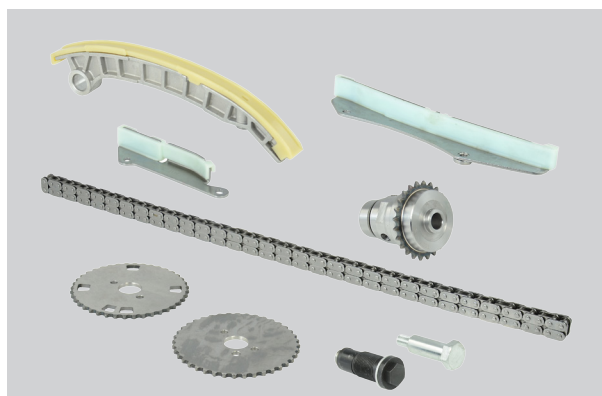

TCK194NG: Chain: Simplex, Closed Link, **122** Links



TCK194LNG: Chain: Simplex, Closed Link, **120** Links

**Note:** Injection Pump Sprocket design on the later version is different due to the shorter chain.



Injection Pump Sprocket



**Best Availability. Best Value.**  
**Best Quality. Best Service.**

TB0002



# Technical Bulletin

## PSA & FIAT IVECO F1CE3481N/D/E (F30DT)

### TCK194NG/TCK195NG vs. TCK194LNG/TCK195LNG

#### Fitting Position: Lower

**TCK195NG** - Engine number to: 1442629 & up to emission standard: Euro IV

**TCK195LNG** - Engine number from: 1442630 & from emission standard Euro V

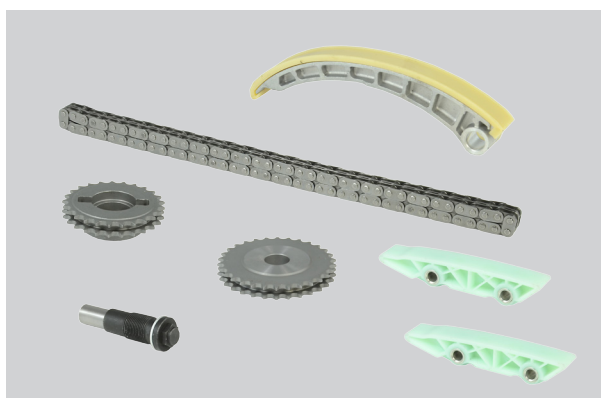

TCK195NG: Chain: Duplex, Closed Link, 84 Links



TCK195LNG: Chain: Duplex, Closed Link, 84 Links

**Note:** Guide rails and crankshaft gear are different.

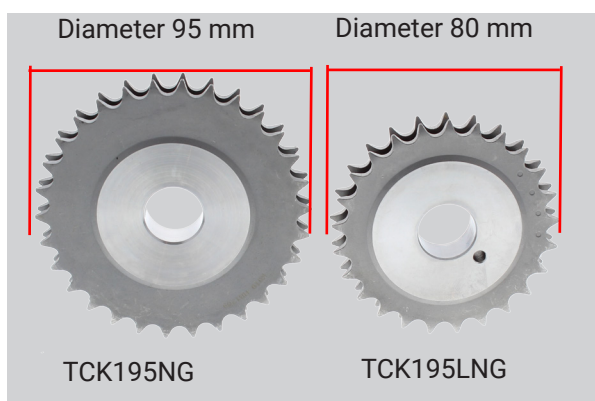

Crankshaft Gear



TCK195NG

TCK195LNG



**Best Availability. Best Value.**  
**Best Quality. Best Service.**

TB0002

