



A Tenneco Company

www.gates.com/europe

023

18/08/08

Technical Bulletin

K02/K035468XS for PSA 1.8 and 2.0 16V engines

GATES REFERENCE:	K02/035468XS
MAKE:	CITROEN / FIAT / PEUGEOT
MODEL:	Evasion, Synergie, XM, Xantia, Xsara, ZX, Ulysse, 306, 406, 605, 806
ENGINE:	1.8 16V, 2.0 16V
ENGINE CODE:	XU7JP4, XU10J4R, XU10J4RS, RFV



On request of the field we will recapitulate the correct use of these kits, depending on the different applications.

PowerGrip® Kit K025468XS is to be used for the PSA **2.0** 16V engines. This kit contains the original manual tensioner (OE ref. 082935, 9622574480. Gates ref. T41258). See Fig. 1.

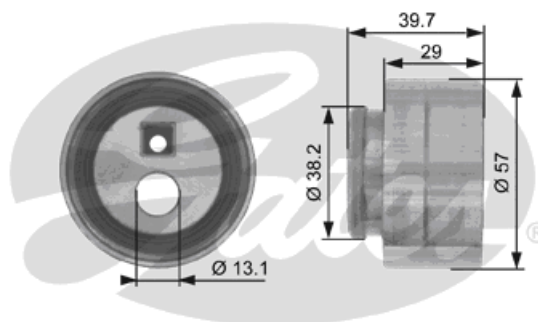

Fig. 1 Manual tensioner (K025468XS)

PowerGrip® Kit K035468XS is only suited for the PSA **1.8** 16V engines. It includes an automatic tensioner (OE ref. 082969, 9635336880. Gates ref. T43050 – see Fig. 2) as an upgrade to the initially installed manual tensioner. This replacement is recommended and also applied by Peugeot/Citroen so the manual tensioner should no longer be used on the 1.8 engine.

Our kit contains a leaflet offering an overview of the complete contents, an application summary and a detailed installation procedure.

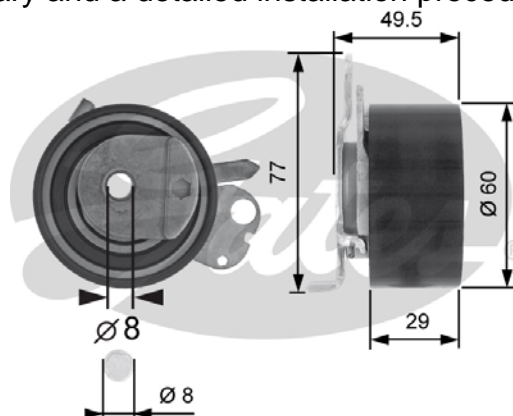

Fig. 2 Automatic tensioner (K035468XS)

An applications overview for the K025468XS and K035468XS can be found at the end of this bulletin. For detailed applications information, please check our web catalogue (or your paper catalogue).



A Tenneco Company

www.gates.com/europe

023

18/08/08

Technical Bulletin

We found out that the drive lay outs we used up to now were not 100% correct: for the 2.0 16V engine, the idler position should be lower in the drive. The correct drawing is shown in Fig 3.

The tension on this 2.0 16V engine has to be checked (with Gates STT-1) between the right camshaft pulley and the idler (enter 5468XS-2).

Our drawings and recommendations on the timing belt/kit boxes will be adjusted accordingly

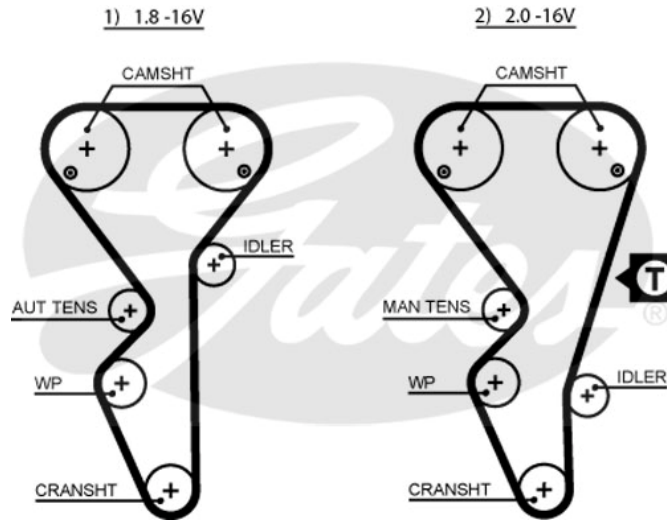

Fig. 3

Applications overview:

K025468XS

CITROEN	Evasion	B	2	XU10J4R	9	1999	10	2002
CITROEN	Synergie	B	2	XU10J4R	9	2000	12	2001
CITROEN	XM	B	2	XU10J4R	8	1994	4	2000
CITROEN	Xantia	B	2	XU10J4R	6	1995	10	2002
CITROEN	Xsara	B	2	XU10J4RS	1	1998	10	2004
CITROEN	Xsara	B	2	XU10J4R	1	1998	8	2000
CITROEN	ZX	B	2	XU10J4RS	9	1996	10	1997
FIAT	Ulysse	B	2	RFV	9	1998	8	2000
PEUGEOT	306	B	2	XU10J4RS	5	1997	5	2001
PEUGEOT	306	B	2	XU10J4R	5	1997	10	2001
PEUGEOT	306 Cabrio	B	2	XU10J4R	5	1997	12	2002
PEUGEOT	406	B	2	XU10J4R	11	1996	8	2000
PEUGEOT	406 Coupe	B	2	XU10J4R	5	1997	12	1999
PEUGEOT	605	B	2	XU10J4R	7	1994	9	1999
PEUGEOT	806	B	2	XU10J4R	10	1998	2	2003

K035468XS

CITROEN	Xantia	B	1.8	XU7JP4	6	1995	4	2003
CITROEN	Xantia	L	1.8	XU7JP4LPG	1	1998	12	2000
CITROEN	Xsara	B	1.8	XU7JP4	7	1997	8	2000
CITROEN	Xsara Estate/Break	B	1.8	XU7JP4	5	1998	8	2000
CITROEN	ZX	B	1.8	XU7JP4	4	1996	10	1997
PEUGEOT	306	B	1.8	XU7JP4	5	1997	4	2002
PEUGEOT	306 Cabrio	B	1.8	XU7JP4	5	1997	12	2002
PEUGEOT	406	B	1.8	XU7JP4	8	1995	8	2000
PEUGEOT	406 Coupe	B	1.8	XU7JP4	10	1997	3	1999

Visit our web catalogue : www.gatesautocat.com