



Dacia Logan Model year: 2006 to 2011 All vehicles with the engine codes K9K, K7J, K4M, K7M

The charging malfunction indicator light is lit

If a customer complains about the above error, it could be caused by a faulty belt pulley on the generator. The customer might also complain about strange noises coming from the V-ribbed belts and the engine. In this case the belt pulley must be checked for damage (see figs 1 and 2) and the generator housing must be inspected. If the belt pulley is damaged, it must be replaced.

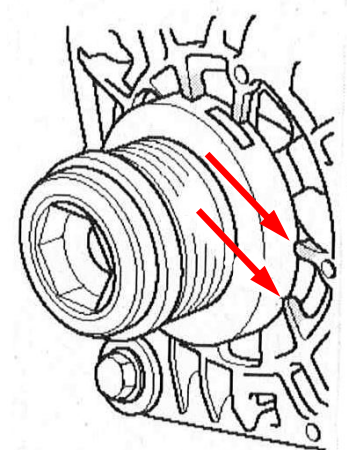

Fig. 1

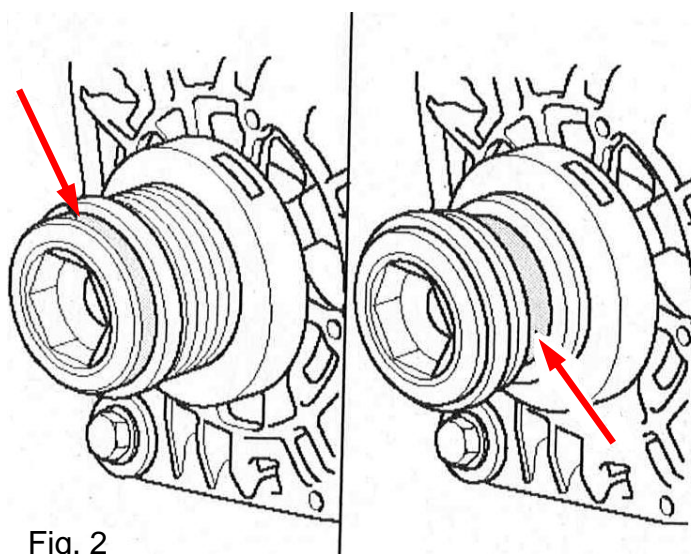

Fig. 2