



## **LED daytime running lights 2PT 980 680-101 to - 861 with simplified assembly**

### **General instructions**

Daytime running lights increasingly gain importance in Europe and beyond. Transport ministers, automobile clubs and car drivers have recognised the clear advantages that these lights provide for safety. From February 2011, all new vehicles (commercial vehicles from mid-2012) must be factory-equipped with special daytime running lights.

. Since major car makers equip their vehicles today with daytime running lights as standard, motivation increases to retrofit one's vehicle with this future-oriented technology.



### **Design and function**

This daytime running light is characterised by its small height and depth dimensions (see the figure).

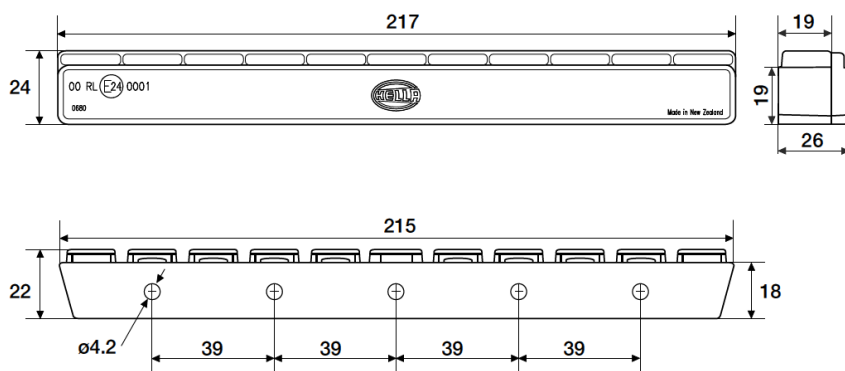

12 LEDs are used as light sources with a power consumption of 2 watts per lamp. They usually last over the lifetime of the vehicle. The LEDs are integral components of the lights and therefore do not have to be replaced. 12 precision lens systems distribute the light emitted from the LEDs in accordance with statutory requirements. The lens made of



transparent nylon in the Swiss Grilamid® technology provides high impact resistance and is resistant to UV radiation and chemicals.

## Installation in the vehicle

In developing these daytime running lights, the focus was placed on simple and uncomplicated installation. For this purpose, the fastening strips are mounted, each with two screws, at appropriate points on the vehicle (e.g., ventilation grilles). Depending on the vehicle front, the cutouts for the lights must be made appropriately.

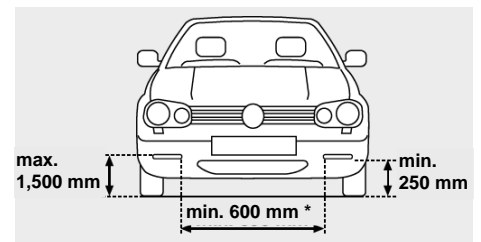

\* On vehicles with a width < 1,300 mm, the distance must be at least 400 mm.

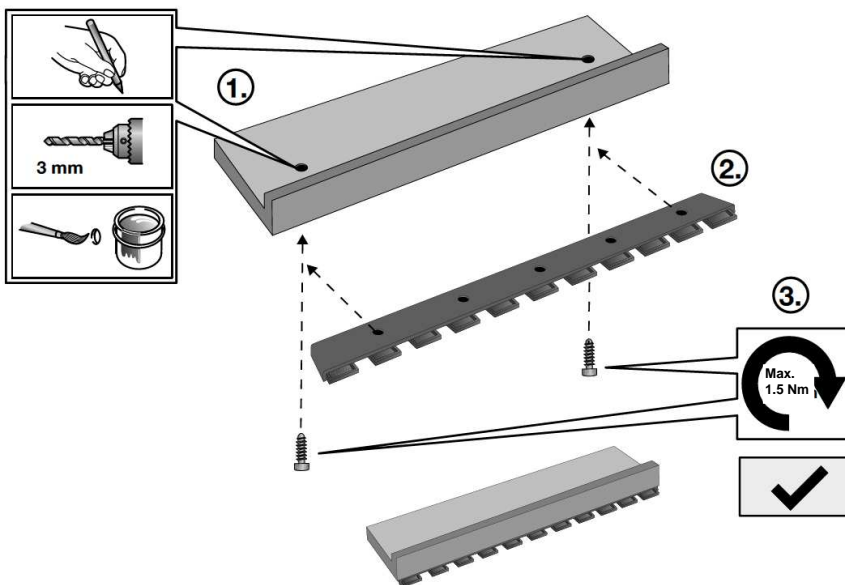

Subsequently the lights are engaged in the fastening strips.

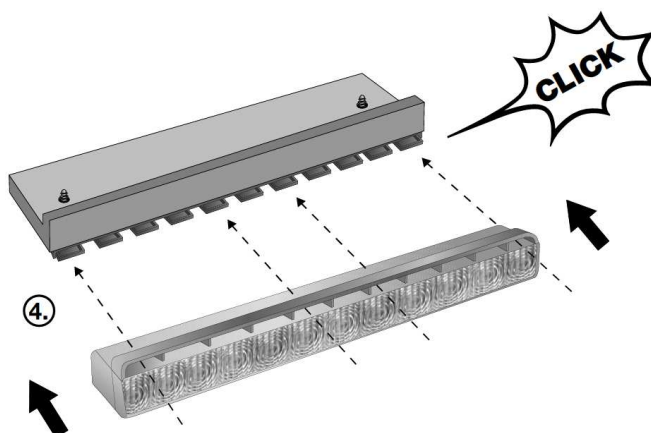

## Electrical connection

The connection is made via terminals 15 (ignition plus), terminal 58 (position light), and terminal 31 (earth). As the lights do not have their own control electronics, a changeover relay is needed for proper functioning.

