



KD457.48

Disassembly/ Assembly recommendations



AUDI:	A4 (Series 2, 2 FL, Cabriolet), A6 (Series 2, 2FL, Allroad), A8	ENGINES	OE reference
SKODA:	Superb	2.5TDi	[059109119B + 059109243J + 059109243L + 059109244B + 059109479B + 059109487C + 0591130113A]
VOLKSWAGEN:	Passat		

TIMING BELT DIAGRAM FOR KIT KD457.48

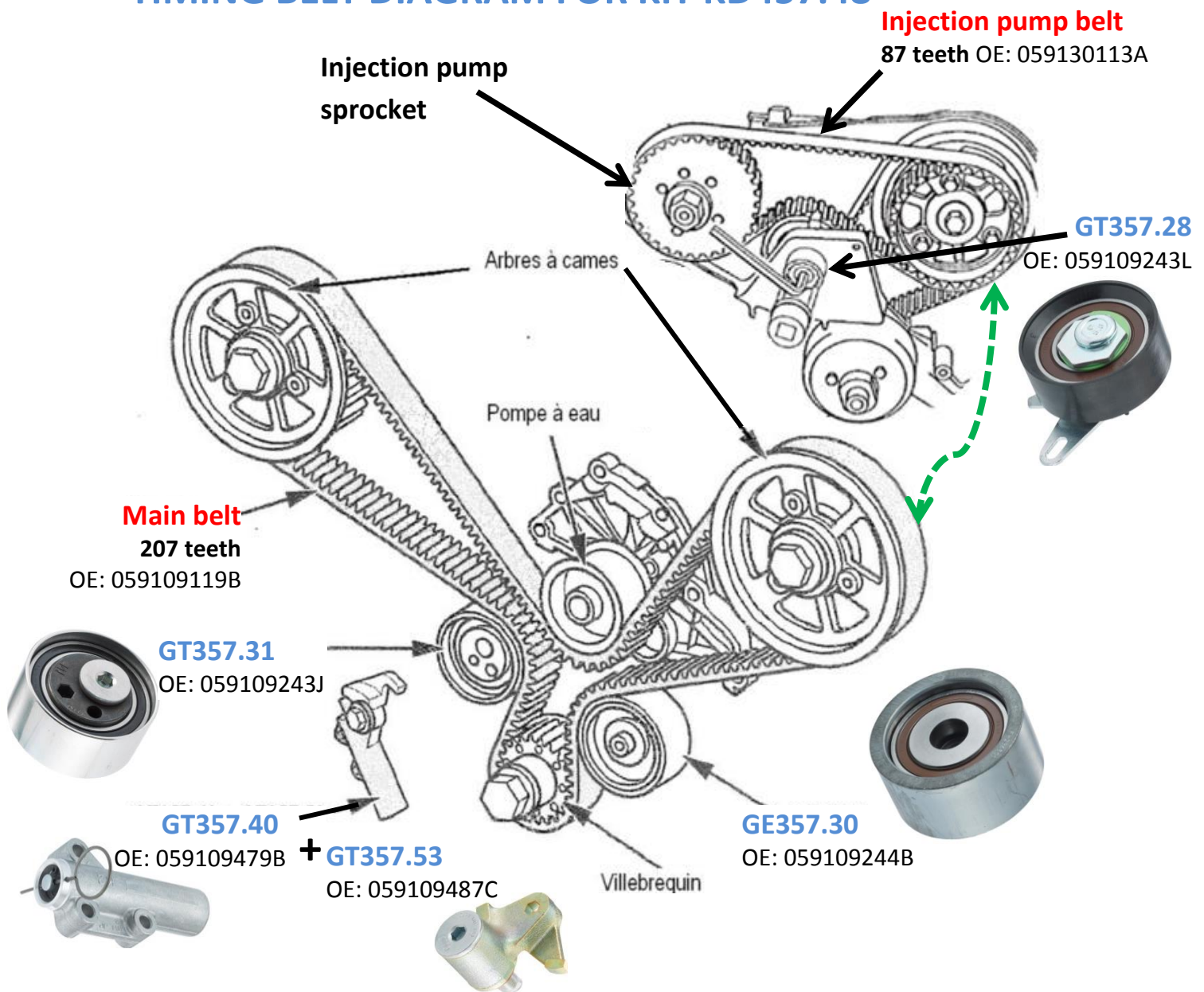

- Note: This kit is sold without roller GT357.53, which is required in order to complete the timing belt system.
- The part number for the kit with the pump included is KDP457.480.

This timing belt kit requires **specialist fitment tools**. (See page 3)



COMMON PROBLEMS

Probable causes

Incorrect installation of GT357.31

This roller requires a particular installation procedure.

The retaining bolt must be fully seated against the washer once the specified tightening torque has been applied. If the bolt is tightened incorrectly or not positioned correctly, it will snap, GT357.31 will then rub against GT357.53 causing damage.



Abrasion mark caused by roller contact

Incorrect tension of GT357.31

- Misalignment of the hole in the shaft of the tensioner and the body of the tensioner indicate a problem with the tension.



Contact mark

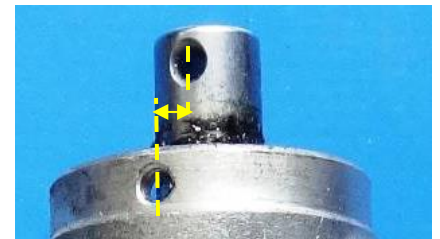

This defect will also cause misalignment and abrasion of the belt.

Incorrect positioning of guide GT357.53

- Be careful to position guide GT357.53 correctly with its stop below that of GT357.31. Incorrect installation will lead to the incorrect tensioning of the roller and result in incorrect belt tension.

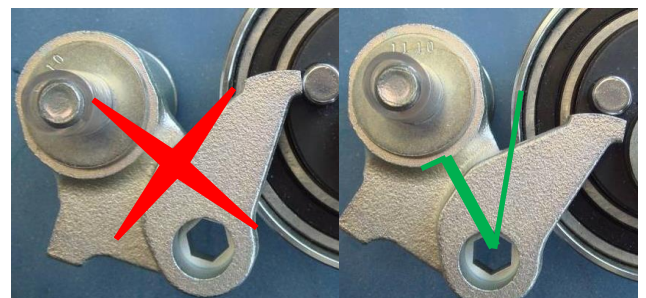

Fracture of the retaining bolt of GE357.30

If the retaining bolt of the roller is not tightened sufficiently or its length is not correct, it will allow the bolt to work in shear fatigue and break.

Fretting marks



Overheating of GE357.30

Tensioner roller installation specifications (see pages 5 and 6) must be followed carefully. Failure to do so may cause misalignment, loss of belt teeth or even overheating due to rubbing.



Incorrect installation of GT357.28

Tool OE (3078) is used to tighten the retaining bolt on GT357.28 an Allen key inserted in the tool is used to adjust the eccentric cam that sets the tension applied by the roller. (See page 7) Incorrect installation can cause the roller's shaft to break or result in incorrect belt tension.



Roller GT357.28 with broken shaft

Incorrect tightening of GT357.28

If the retaining bolt has not been tightened correctly using the correct torque setting, the correct tools, or the washer has been left off or incorrectly installed, the lower stop marker will to move backwards and forwards too much and hit the stops this leaves damage on both stops. If the tensioner is correctly adjusted the lower marker will never hit the stops.



The 6 faces underneath GT357.28 are not involved in the operation of the roller. Never tighten or loosen it.



All retaining bolts require a tightening angle in addition to their tightening torque, or thread locking agent being applied when replacing the components.

Incorrect arrangement of hydraulic tensioner GT357.40

When using a hydraulic tensioner, precautionary measures must be taken during installation.

- Never remove the locking pin from the tensioner before it has been securely fastened in place.

Component seizure

A seized component will cause the belt to overheat, due to friction caused by the belt slipping over the seized component this then causes other components to overheat and break up (bearing grease, rollers, casing).



Consequences of belt slippage



The most common cause of this failure is a water pump seizure. It is recommended that the water pump is changed when a timing belt is replaced.

Consequences

Engine damage

These malfunctions generally result in a costly engine failure.

REPLACEMENT

Special tools

- Crankshaft locking tool OE (3242)
- Camshaft locking tool OE (3458)
- Counter bearing OE (3036)
- Extractor OE (T40001)
- Centring arbor OE (3359)
- Socket spanner set OE (3078)

SNR recommends using HAZET tool set 4794/48 and extractor no. 2510-1

Tightening torques

- Tensioner roller bolt GT357.28: **37 Nm**
- Tensioner roller bolt GT357.31: **42 Nm**
- Idler roller bolt GT357.28: **45 Nm**
- Hydraulic tensioner roller bolt : - **M6: 10 Nm**
- **42 Nm**
- Camshaft centre bolt: **75 Nm**
- Camshaft eccentric bolt: **22 Nm**
- Injection pump vibration damping bolt: **22 Nm**
- Crankshaft pulley bolt: **200 Nm + 180°**
- Plug: **10 Nm**
- Wheels: **120 Nm**



Tightening torques may differ from vehicle to vehicle, so it is recommended that tightening torques are checked against the specified manufacturer settings.

Removal of the injection pump belt

1) Before commencing with the installation, make sure that:

- The engine is cold.
- The engine is at TDC (top dead centre) on the first cylinder.
- The timing marks are aligned.
- The camshaft timing gauge is in place.
- The battery is disconnected.

2) Remove the front guards and the accessory belts

3) Remove the oil filler cap

The mark on the camshaft should be visible through the oil filler opening.

Camshaft

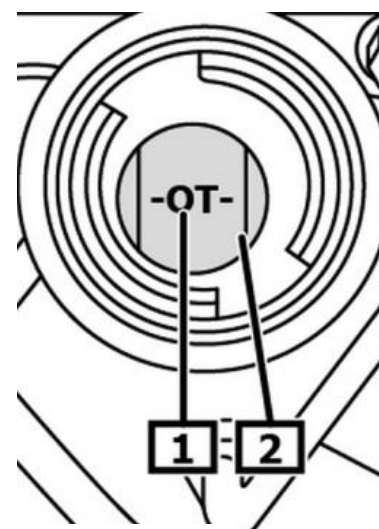

1 Marquage(s)

2 Orifice de remplissage d'huile

Crankshaft

- 4) Tighten the crankshaft locking tool (no.3)
- 5) Disconnect and remove the coolant system components
- 6) Remove the vacuum pump on the left side of the engine
Leaving the hoses connected
- 7) Remove the TDC mark plug on the right side of the engine
This plug must be re-installed later, so be careful to avoid damaging the sealing surfaces
- 8) Install locking tool OE 3458 (no.5) at the two ends of the camshaft (no.4)
- 9) Unscrew the bolt with the counter bearing and remove the vibration damper

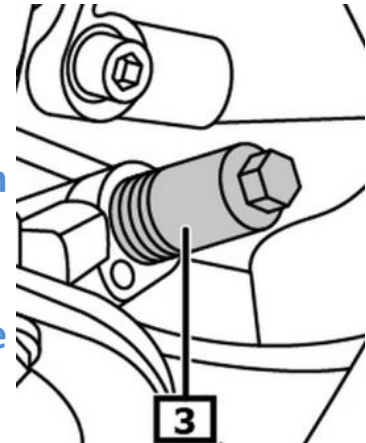

Do not loosen the centre bolt of the injection pump wheel.

- 10) Rotate GT357.28 (no.3) CLOCKWISE using a spanner and tool OE 3078
- 11) Remove the injection pump belt (87 teeth)
- 12) Remove the timing belt guard
- 13) Unscrew the 3 bolts (no.6) on the camshaft wheel (no.4) and loosen the central bolt (no.7)

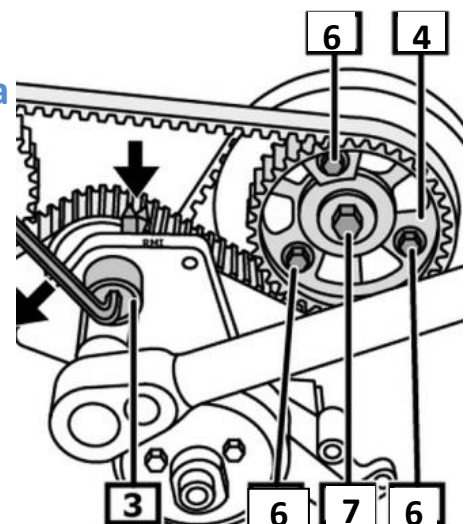

Removal of the main belt

- 1) Rotate tensioner roller GT357.31 (no.1) **CLOCKWISE** with a spanner (no.2)
- 2) Block the hydraulic system (no.3) with a rod (no.4)
- 3) Use an extractor to remove the camshaft wheels
- 4) Remove the main belt (207 teeth)

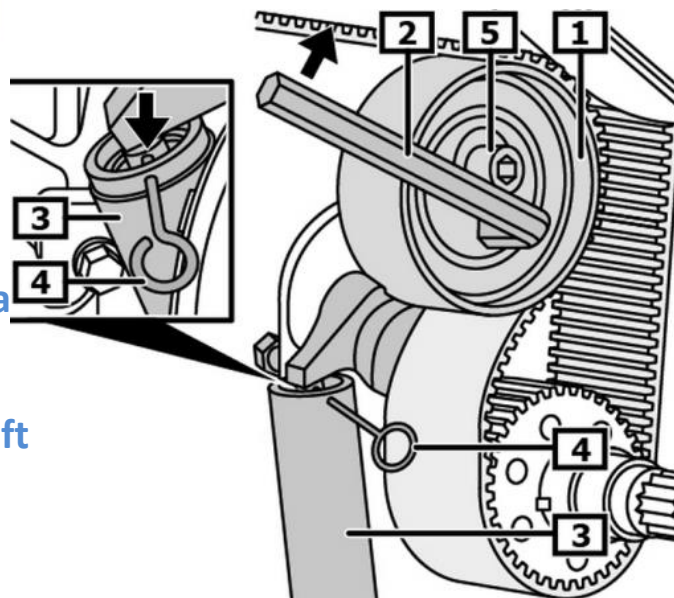

Re-installation of the main belt

- 1) Position the engine to TDC cylinder 1
- 2) Install roller GT357.31 (no.1)
Making sure the washer is correctly fitted

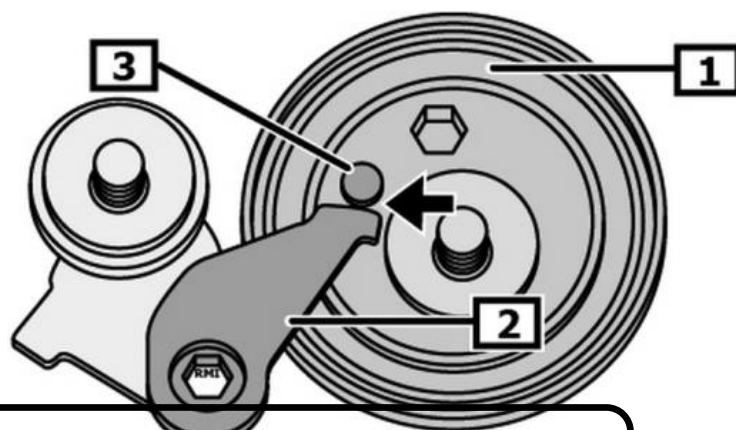

Make sure that the tensioner lever (no.2) is under the stop (no.3) of the tensioner pulley (no.1).

- 3) Install the camshaft locking tool and then the crankshaft locking tool
- 4) Re-install the main belt in the following order:

207-tooth belt (no.7)

- Crankshaft pulley (no.9)
- Camshaft wheel, right (no.6)
- GT357.31 + GT357.53 (no.4)
- GE357.30 (no.10)
- Water pump pulley (no.8)
- Camshaft wheel, left (no.5)

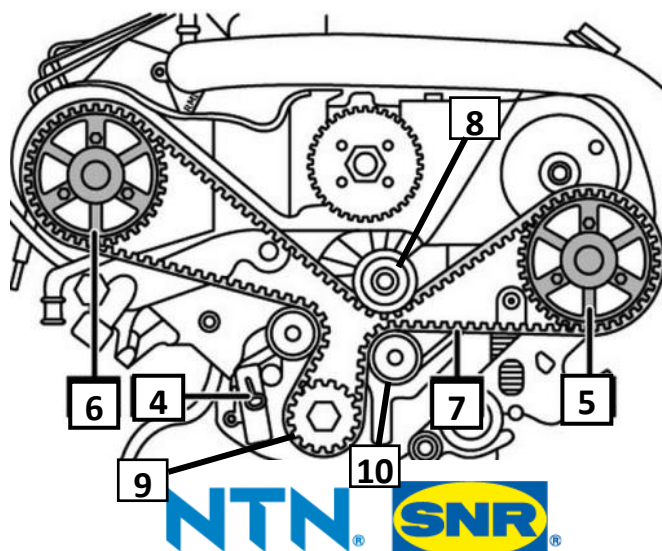

- 5) **First loop the belt loosely over the left camshaft sprocket (no.5), then install that sprocket on the camshaft**
- 6) **Install the camshaft bolts**
without tightening them completely: the wheel should still be free to rotate on the taper.
- 7) **Rotate GT357.31 CLOCKWISE**
Remove the hydraulic system locking tool
- 8) **Pre-tension GT357.31 ANTI-CLOCKWISE**
by applying 15 Nm of torque to the eccentric adjuster
- 9) **Tighten the central camshaft bolts securely**
- 10) **Re-install the timing belt guards**
- 11) **Install the injection pump centring arbor**
- 12) **Screw in the eccentric screws of the left camshaft**
without tightening them all the way

Re-installation of the injection pump belt

- 1) **Re-install the belt (87 teeth) in the following order:**
 1. **Camshaft**
 2. **Injection pump**
 3. **GT357.28**

- 2) **Position tool OE (3078) and the Allen key on tensioner GT357.28**
- 3) **Rotate the Allen key ANTI-CLOCKWISE by means of tool OE (3078)**

The indicator must be aligned with the positioning pin mark

- 4) **Tighten the mounting bolt on GT357.28 while holding the Allen key in place**
- 5) **Tighten the eccentric bolt of the camshaft**
- 6) **Remove and re-install all of the tools to verify the belt tension**

Reposition the engine to TDC on cylinder 1

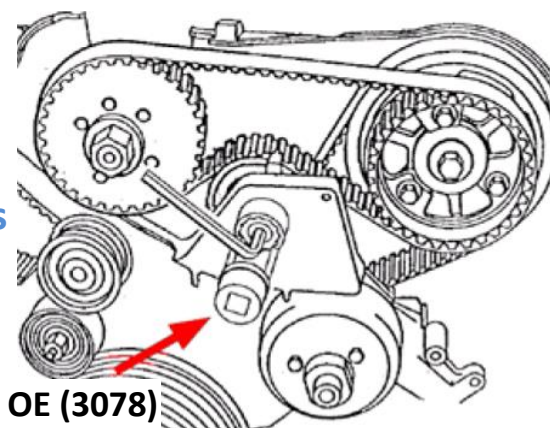



Remember to install the camshaft plug.

Check the bushings of GT357.53

- 1) Unscrew the bolt (no.1) and pivot tensioner GT357.53 (no.2) to the side
- 2) Check that the rotation of the bearing (no.3) is correct and that there is no corrosion or damage, if in any doubt replace the bearing.

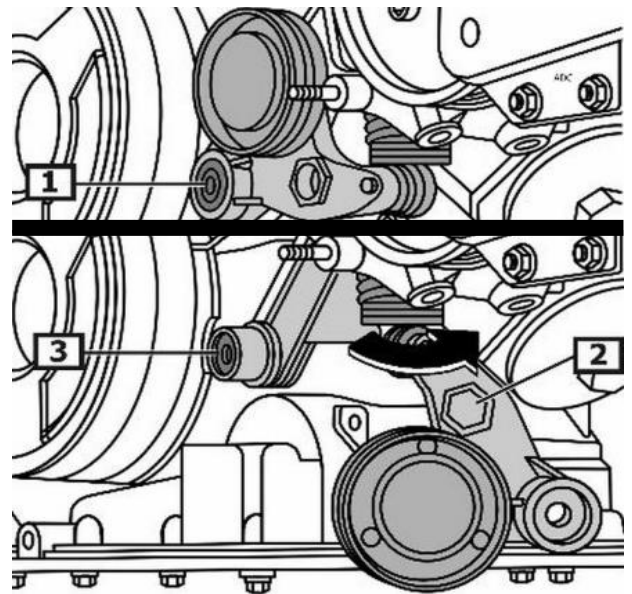

Re-install the remaining components in the reverse order to that in which they were removed



Recommendations

Replace the belts every 120,000 km (75,000 miles) inspect them every 30,000 km(18000 miles)

Do not rotate components while the belts are removed.

ALL parts, rollers, idler rollers and tensioner rollers should always be replaced never just the belt.

Follow the vehicle manufacturer's installation procedures and apply the specified tightening torques.

Refer to the vehicle applications in our online catalogue: <http://lc.cx/catalog-ra>



Scan this QR code to access our online catalogue.

The contents of this document are the copyright of the publisher and any reproduction, even partial, is prohibited without permission. Despite the care taken in preparing this document, NTN-SNR Roulements disclaims any liability for errors or omissions that may slip through, as well as for losses or direct or indirect damage arising from its use.

©NTN-SNR ROULEMENTS

FOLLOW THE RECOMMENDATIONS OF THE VEHICLE MANUFACTURER.

NTN 