



Cylinder Liners for OM 541/542/457 Euro 4/5

Change of liner flange counterbore and sealing

Vehicle / engine	Product
Mercedes-Benz OM 541/542 Euro 4/5	Cylinder liner KS No. 89 846 110
Mercedes-Benz OM 457 Euro 4/5	Cylinder liner KS No. 89 847 110; 89 867 110



Fig. 1: Cylinder liner

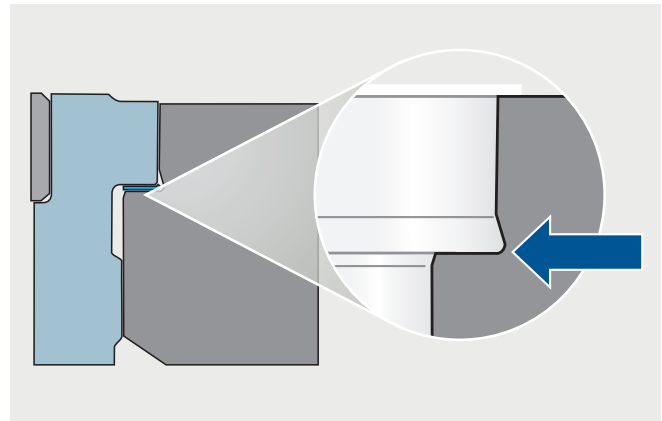

Fig. 2: Fitting situation (example: Mercedes-Benz Actros)

Situation

The emission classes Euro 4 and 5 have initiated modifications of the cylinder liners. The new cylinder liners contain an additional fire ring (see fig. 1). The tombak sealing shim under the liner flange has been replaced by a larger stainless steel sealing shim.

The steel shim's higher abrasion resistance reduces wear between cylinder liner and engine housing.

The liner flange counterbore in the engine block has also been modified. The diameter of the flange recess in the engine block is designed with an undercut to hold the larger sealing shim (fig. 2).

The fitting tolerance between the flange's outer diameter and the liner flange counterbore in the engine block is lower than that of its predecessor. The modifications were made by the manufacturer to minimise the relative movement between cylinder liner and cylinder block.



Attention:

Despite the relatively tight fit of the cylinder liners in the main bore, micromovements occur due to the combustion pressure and the lateral piston forces during engine operation. These movements cause the liner flange to dig into the engine housing.

The constructive modifications have been made to reduce engine wear. Only thereby can the required mileage for utility vehicles of over a million kilometres be ensured.