



Failure of secondary air pump due to jammed relay

Vehicle:	Product:
All petrol-driven vehicles with secondary air system	Secondary air pump

Potential complaints:

- Secondary air pump does not start after a cold start
- The engine compartment smells charred
- Melting traces on the electrical contacts of the secondary air pump
- P0410 “Malfunction”

These conditions indicate that the secondary air pump has failed due to overload.

Possible causes

The relay via which the secondary air pump is controlled is jammed.

As a result, the secondary air pump was energised for an impermissibly long period of time.

During a cold start, the secondary air pump may only be in operation for a maximum of 90–120 seconds.

The secondary air pump is not designed for continuous use!

Checking:

- Identify the respective relay by means of the circuit diagram.

With cold vehicle engine (“cold start”):

- The secondary air pump has to start audibly after a cold start of the engine.
- If the power supply of the secondary air pump is fine, but the secondary air pump runs with a scraping, whistling or scratching noise or not at all, the secondary air pump is to be replaced.
- We recommend replacing the relay as well.
- In such cases, all other secondary air system components should also be checked.

With warm vehicle engine:

- Start vehicle engine.
- Check electrical contacts of voltage supply to secondary air pump.
- The relay is jammed if voltage is present at the secondary air pump.
- Replace relay and secondary air pump.

Final check:

- The secondary air pump has to run for about 90–120 seconds after a cold start of the engine.



Damage: melting traces on the housing (top view into the housing)



Damage symptoms: melting traces on the electric motor or on the electrical contacts



View into the secondary air pump (cut)
with melting traces

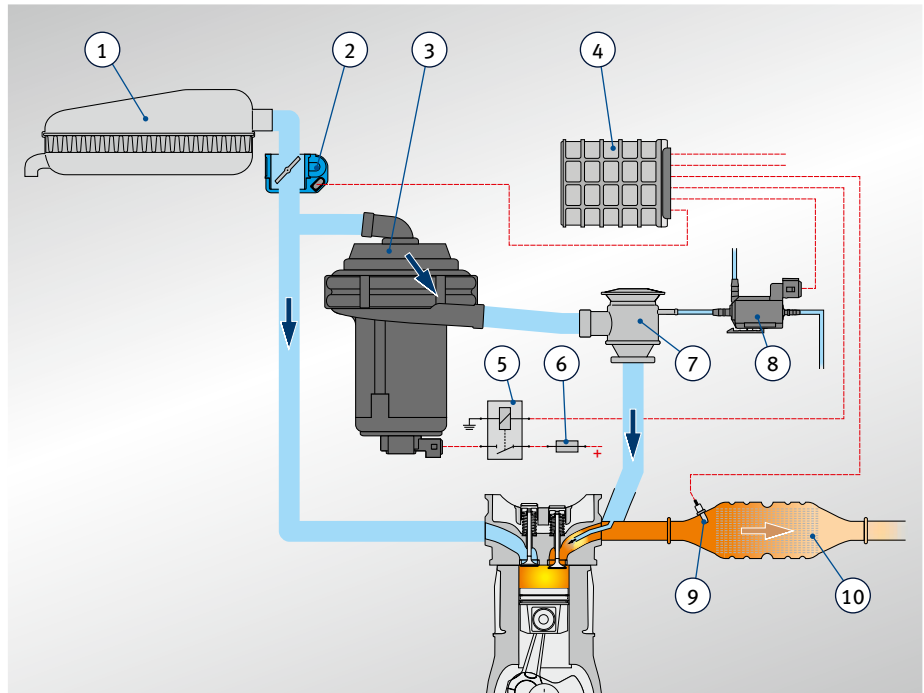

Block diagram of secondary air system (pneumatically actuated)

- | | |
|-------------------------------|------------------------------|
| 1 Air filter | 6 Fuse of secondary air pump |
| 2 Throttle valve | 7 Secondary air valve |
| 3 Secondary air pump | 8 Electric switchover valve |
| 4 Engine control unit | 9 Lambda sensor |
| 5 Relay of secondary air pump | 10 Catalytic converter |

Fast facts: Secondary air system

A “rich mixture” ($\lambda < 1$), i.e. a mixture with excess fuel, is required for cold start of a petrol engine.

Thus, large amounts of carbon monoxide and unburned hydrocarbons are produced during cold start.

To reduce the level of these pollutants, ambient air with a high oxygen content (secondary air) is injected into the exhaust manifold directly downstream of the exhaust valves during the cold start phase.

This results in post-oxidation (afterburning) of the pollutants to form carbon dioxide and water.

The heat generated in this process additionally warms the catalytic converter and speeds up the start of Lambda control action.