



Oil Circuit Pressurizing Procedure

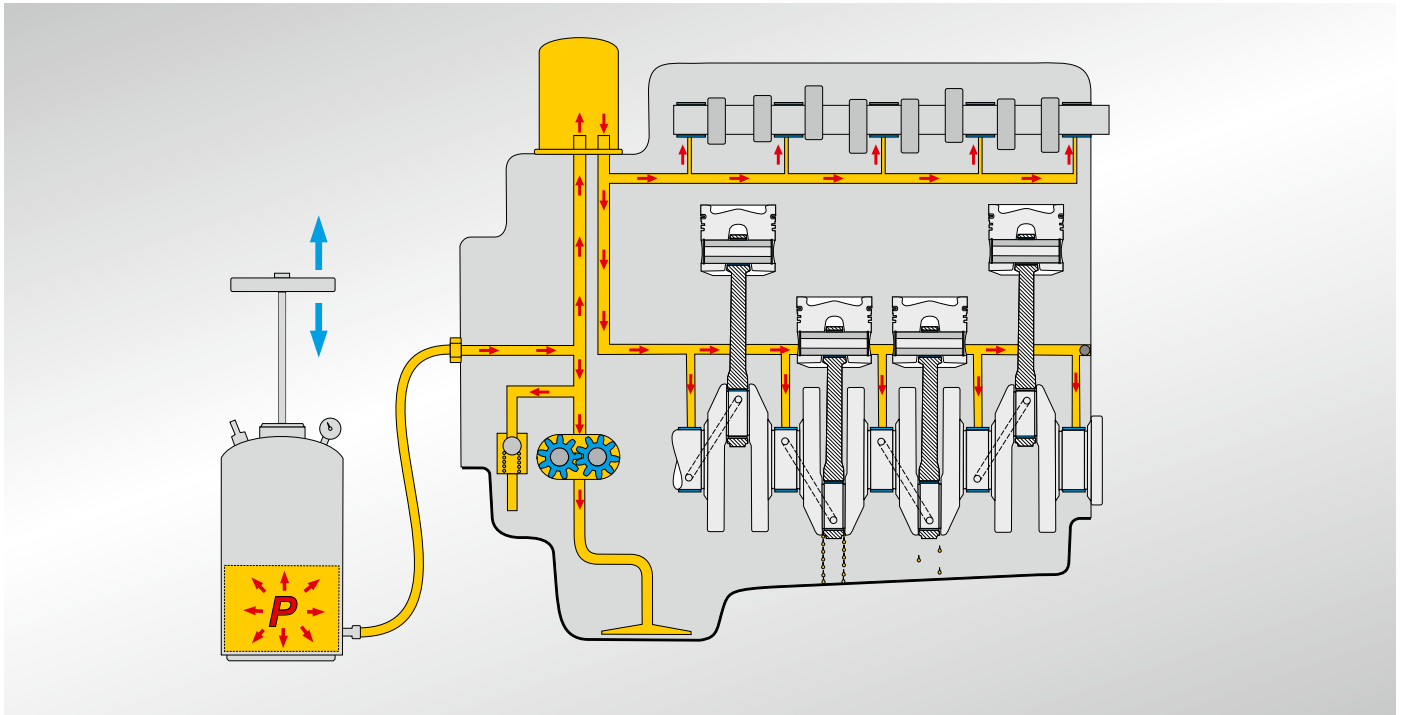

Fig. 1

Situation:

At the first start-up after a complete overhaul of an engine, sometimes damages occur in the different plain bearing locations. The problem occurs because the oil pressure system has not yet been filled with oil and the engine lubrication system fully pressurized with the correct grade of lubrication oil. Only when the oil pressure system has been correctly filled with oil and the system is free of any air, can oil pressure be built up by the engine oil pump. If an engine is started in a dry state, under certain circumstances it will take too long until the oil reaches the plain bearing locations. It is for precisely that reason the connecting rod bearings suffer extreme damage under these condi-

tions. During this time the bearings have no oil supply other than the oil used during bearing assembly. Emergency reserves are then quickly used up, and the bearings get damaged by friction and overheating. It is also characteristic of new or overhauled engines for the engine startup to be delayed due to the empty fuel lines and for the starter to have to be actuated, often for several minutes, before the engine will start up. Even in the case of an oil change with filter, the plain bearings of certain truck engines can be damaged because the new oil does not reach the bearing locations fast enough.

The Solution:

To avoid damage at the first startup, we recommend in any case that the oil pressure system be filled with engine oil manually before starting the engine. This will ensure that any air that is in the oil pressure system will be removed and will guarantee that all the components will function safely from the beginning. In addition to the plain bearings, the hydraulic chain tensioners, camshaft phasing devices, hydraulic tappets and also engine components lubricated with engine oil such as turbochargers, fuel pumps, injection pumps and vacuum pumps benefit from this process as well.

The right of changes and deviating pictures is reserved. For assignment and replacement parts, refer to the current catalogues, TecDoc CD or respective systems based on TecDoc.

Note:

This process is generally prescribed by many well-known engine manufacturers before starting a new or overhauled engine for the first time.

Procedure:

1. With the assistance of a pressure tank, at least 30% of the normal engine oil capacity is pumped into the engine through a threaded connection in the oil pressure system (Figures 1 and 2). The screw plugs provided by the engine manufacturer are the most suitable connection points for this purpose. If no such plugs are available, a plug can be removed from an oil hole or an oil pressure switch to make the connection, if necessary.



Fig. 2

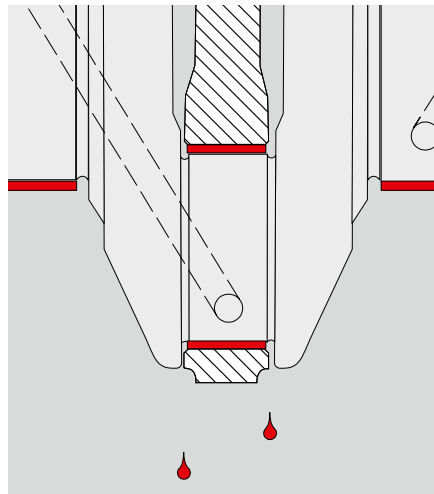

Fig. 3

2. Oil will now be pumped into the engine until it flows out bubblefree at the lubrication points farthest from the oil pump. These locations are usually the rocker arm bearings or the bearing locations of camshafts in high positions. The pressure of the oil fed in should not exceed the oil pressure that usually dominates in the engine.

3. Furthermore, attention must be given to the oil level in the oil container, that it does not drop to the minimum level during filling, because if it does, air could get into the oil system again, and the whole process would have to be repeated.

The process is also a very good way to judge whether the overhaul and installation of the crankshaft with the appropriate plain bearings was done according to specification.

To do this, the oil pan is removed and the oil escape of the crankshaft plain bearings is checked while pressure is being applied, as illustrated in Figures 3 and 4. Here, irregularities in the oil outflow will be noticed immediately.

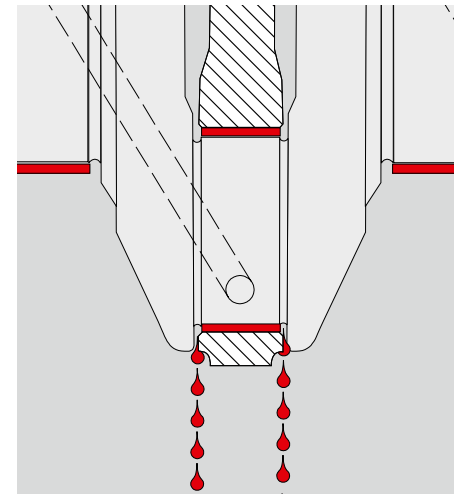

Fig. 4

If a plain bearing is intact, a few drops of oil will leak out (Fig. 3), while a faulty plain bearing will have a far greater oil leakage or no leakage at all. If too much oil escapes from one plain bearing in comparison to the others (Fig. 4), it can be assumed that the bearing clearance is too big. Possible causes are the installation of wrong plain bearing shells or a bearing journal that was ground too small or is worn. No oil escape, on the other hand, points to incorrectly seated bearing shells or clogged oil channels. Here in any case the cause must be eliminated and the pressure application process repeated. In the case of engines with piston spray cooling, the functioning of the oil spray nozzles and the direction in which they spray can also be checked.