

PSA radiator modifications

For Vehicle: All PSA models

The Valeo Service Technical department have had several radiators returned with customers stating that there are several differences on the unit supplied compared to that of the one being taken off the vehicle. When the unit has been inspected no defects have been found on the radiators and the design is the same as the radiators supplied by Citroen and Peugeot.

Please be aware that Citroen and Peugeot have implemented several design changes to their radiators to ensure they are easier to fit and reduce the chances of any leaks occurring. The design changes are as follows:

Radiator Cap Modification

On a variety of PSA vehicles the radiator cap has now been modified from the original bayonet design to a screw type/threaded design. The modification was implemented to ensure that a tighter seal is made on the filler neck and stop any leaks.

To integrate the new design the filler neck on the radiator itself had to be redesigned to remove the bayonet type fitting and add a threaded connection.

As you can see on the diagram to the right PSA will provide only one radiator but a radiator cap for the original bayonet type connection (2) and a radiator cap for the newer threaded type connection (3). Where the radiator has been modified the design of radiator supplied by PSA and therefore Valeo will be the newer design for the threaded radiator cap.

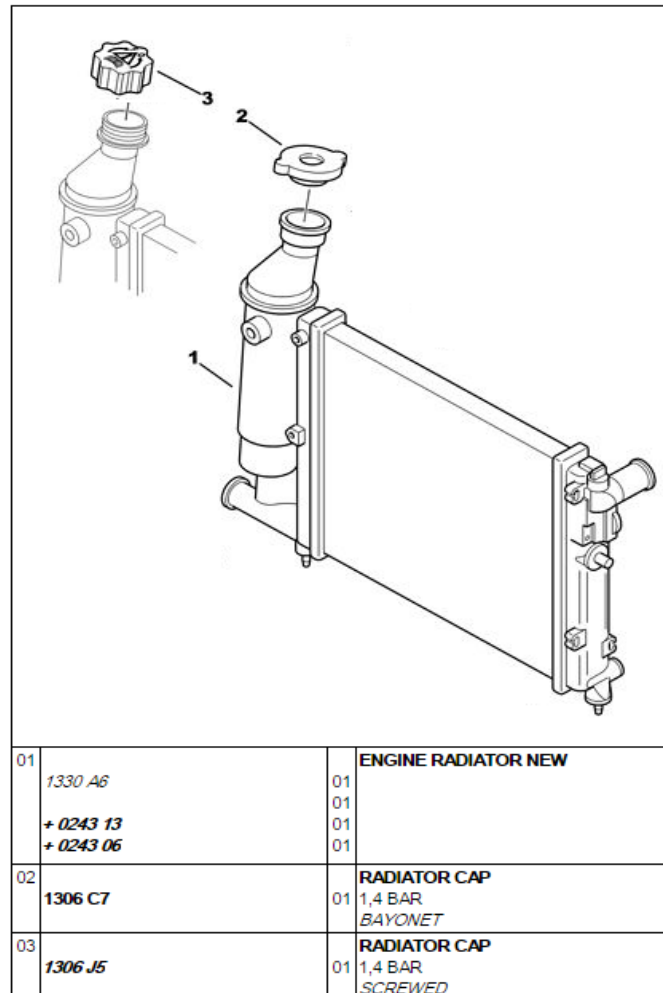

PSA radiator modifications

Modified Hose Connections

The second modification by PSA is the radiator hose connections. The original design of the radiator hose has bayonet type connections that require spring loaded clips to hold the hose on to the radiator inlet/outlet. The newer design of the radiator has quick connect connections. The modified radiators of this design require new hoses.

As you can see on the diagram to the right PSA will provide only one radiator but under the radiator part number (1330 A6) there will be two additional part numbers prefixed by a + (0243 13 and 0243 06). These additional part numbers are the new design hoses with the quick connect type connection. to suit the modified radiator. These must be supplied when the new design radiator is fitted.

The design of radiator supplied by PSA and therefore Valeo will be the newer design with the quick connect type hose connections.

